

DATA SHEET

INSERTER

Ref : 2333

Type : INSERTER
Brand : COUNTEC
Model : SG-120
Serial N° :
Year : 2025
Quantity : 1
Overall dimensions : 1.80 x 0.90 x 1.95 M
Weight : 180 Kg



// Suitable for inserting sachet silica gel desiccant in roll form

Description:

Operational principle:

Designed to use silica gel sachets in roll form. Sachet fed to cutting station by side gripping belts.

Cutting by reciprocating knife action. Sachet inserted into bottle with plunger action.

Sensors detect end of sachet roll, eye mark, sachet insertion, stepping motor drive starting point and bottle feed condition.

No change parts required

End of roll visual/audio warning

Multi-shot insertion (up to 2 sachets per container)

Auto sachet blank-distance deviation control, alarm and stop machine

* If the distance between 2 sachets is over the setting range.

Incorporates a safety guarding

Container spacer gate

No bottle/back up control sensor, stop machine and auto restart

Container Diameter 25 to 120 mm

** This machine can handle up to dia. 135mm by machine modification with extra charge.

** The bottle sample checking is mandatory.

Height 40 to 200 mm

** Any bottle size out of above standard range has to be checked the samples by COUNTEC.

Speed Up to 100 bottles per minute (based on single cut)

Construction AISI 304 stainless steel meets GMP regulations

Silica gel detection Sachet thickness (or Eye-mark)

Sachet length range 27 - 70 mm

Sachet width range 16 - 50 mm

Sachet weight 0.5 - 5g

** Any sachet size out of above standard range has to be checked the samples by COUNTEC.

Sachet roll I/D 76 mm

Sachet roll O/D 360 mm

DATA SHEET

INSERTER

Ref : 2333

Type : INSERTER
Brand : COUNTEC
Model : SG-120
Serial N° :
Year : 2025
Quantity : 1
Overall dimensions : 1.80 x 0.90 x 1.95 M
Weight : 180 Kg



// Suitable for inserting sachet silica gel desiccant in roll form

Description:

Sachet roll thickness 300 mm
Container neck I/D should be minimum 5mm larger than Sachet width.
e.g. Sachet width 20 mm - Container neck I/D more than 25 mm
Specification
Machine dimension 1 800 (L) x 900 (W) x 1 950 (H) mm
Weight Approx. 180 Kg
Electricity supply 220V, 1 phase, 50/60 Hz
If the utility

// Suitable for inserting sachet silica gel desiccant in roll form

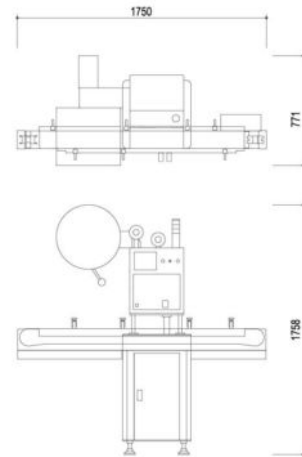
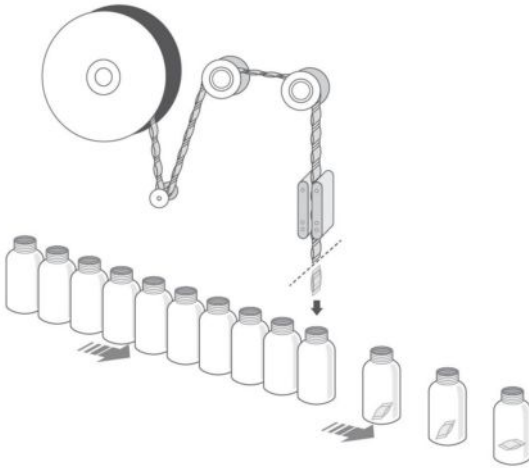

Video link

https://www.youtube.com/embed/B02_esyUh6g?si=LPKxABTGcDf3NSq0 title="YouTube video player"

